

SYNTAX ERROR²

enhanced audio computer system



USER MANUAL

CONTENTS

BASIC OPERATION.....	<u>3</u>
INS AND OUTS	<u>3</u>
CONTROLS & DISPLAY	<u>4</u>
PRESETS.....	<u>5</u>
EXPRESSION PEDAL	<u>6</u>
SOUND MODES	<u>7</u>
MINI-SEQUENCER.....	<u>8</u>
GLOBAL CONFIGURATION	<u>9</u>
STEREO MODES	<u>10</u>
MIDI	<u>11</u>
SPECIFICATIONS.....	<u>12</u>

MANUAL VERSION 1.01
DECEMBER 2021

ABOUT ALEXANDER PEDALS

Alexander Pedals builds hand-crafted effects pedals in Garner, North Carolina. Each Alexander Pedal is meticulously voiced and tweaked by our sonic scientists to achieve sounds that are both instantly familiar yet completely unique.

Alexander Pedals are designed by Matthew Farrow and a group of trusted players, builders, and friends. Matthew has been building guitar pedals since the late 1990s, first with Pharaoh Amplifiers, and now with Disaster Area Designs. Matthew has designed some of the most innovative effects units on the market, including some big names he's not allowed to tell you about.

Alexander Pedals was started for two reasons - to make great tones, and to do good. The great tones part you probably have some idea about. As for doing good, Alexander Pedals donates a portion of the profits from every pedal sold to charity, whether you buy from us or our dealers. Matthew's younger brother Alex passed away in 1987 of a form of cancer called neuroblastoma. Alexander Pedals honors his memory by helping in the fight to end childhood cancer.

ALEXANDER
GREAT TONES. DOING GOOD.
alexanderpedals.com

BASIC OPERATION

Welcome to Weirdville, population: you.

The Alexander Syntax Error² is our newest noisemaker, designed to help you create your very own arcade soundtrack using guitar, bass, keys, or whatever.

Using the pedal is pretty simple: plug your instrument into the black INPUT jack and your amplifier or other effect into the white L / MONO jack, power up the pedal with 9V 250mA or more, and turn some knobs. You'll be rewarded with strange sounds and twisted tones courtesy of the Syntax Error²'s FXCore DSP processor and our own custom microcontroller interface.

This manual contains full technical details on the operation of this pedal. For more information regarding firmware updates, update tools, and software integration, please scan the code in this section to visit our website.

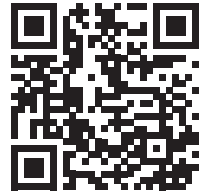

scan me for
more info!

INS AND OUTS

- INPUT:** Instrument input. Defaults to mono, may be set to TRS Stereo or TRS Sum using the Global configuration menu.
- R / DRY:** Auxiliary output. Defaults to sending the unaltered dry signal, may be set to output the right side of the stereo output using the Global configuration menu.
- L / MONO:** Main output. Defaults to mono output, may be set to output the left side of the stereo output using the Global configuration menu. May also be used as a TRS stereo output (disables the R / DRY jack) if the next effect or input is TRS stereo.

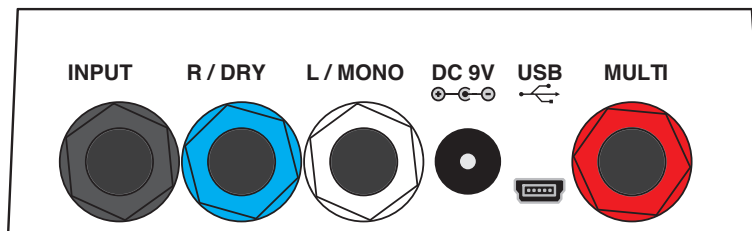

- DC 9V:** Center-negative, 2.1mm ID barrel jack for DC input. The pedal requires a minimum of 250mA to operate, higher current supplies are acceptable. Do not power the pedal from a source greater than 9.6V DC.
- USB:** USB mini-B connector for USB MIDI or firmware updates
- MULTI:** User configurable jack, used for Expression pedal (TRS only,) remote footswitch, or MIDI input / output (requires converter unit or adapter cable.)

CONTROLS & DISPLAY

The Syntax Error² is a pretty complex pedal under the hood, but we worked hard to make sure that it's easy to drive.

We combined a simple user interface with a high-resolution OLED display to get you the maximum tweakability with the minimum frustration.

The A B X Y knobs adjust the effects parameters or sequence steps, as shown on the display.

The MIX / Data knob adjusts the overall wet / dry mix, or the data value for the selected parameter in the sequencer or config menu.

And the MODE knob is an endless rotary encoder with push switch. Turn the knob to select a new sound mode or menu item. Tap the knob to move to the next page or to edit the selected item. Finally, you can hold it to access the pedal menu.

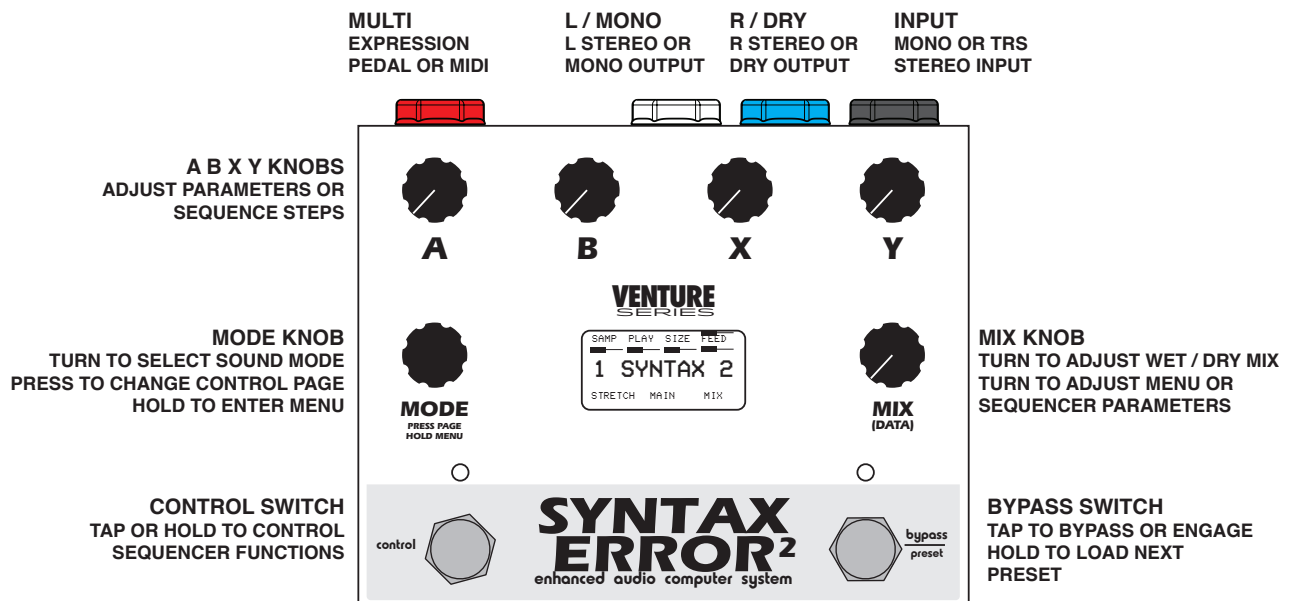

The display shows the current function and position of each knob, as well as the sound mode, preset name, and page name. If you're using an expression pedal, the display will also show the pedal position while it's moving.

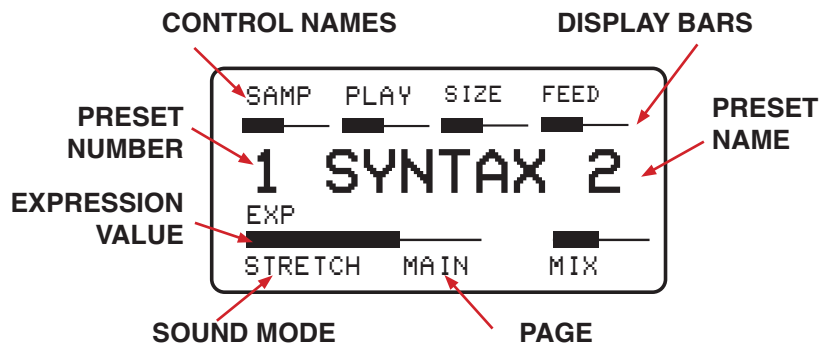

PRESETS

How do you make quick changes on a pedal that has 9+ knobs? PRESETS. The Syntax Error² allows you to save up to 32 presets that contain the entire state of the pedal.

Loading a preset recalls all knob positions, sequence steps, sequencer settings, and expression pedal mappings.

To load a preset, hold the BYPASS / PRESET footswitch. You can set the number of available presets in the Setup Menu, from 1 to 8. You can also set the pedal to access the upper banks of presets (9-16, 17-24, 25-32) in the same menu. This allows you to use multiple banks of presets for different gigs, bands, instruments, whatever you like.

You can also use an external MIDI controller to load any preset from 1-32, regardless of how the Setup Menu is configured.

To save a preset, first use the pedal knobs to tweak the sound, then hold the MODE knob. Press and hold the BYPASS / PRESET footswitch to enter the save menu.

If you want to save to the current preset, you can just hold down the BYPASS / PRESET footswitch again. If you prefer to rename the preset, turn the MODE knob to select a character in the name and then tap the MODE knob to edit that character. Use the MODE knob to select the preset number and edit to change the save location.

TURN TO SELECT
CHARACTER OR
PRESET

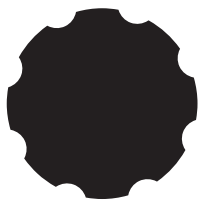

MODE
PRESS PAGE
HOLD MENU

TAP TO SELECT
CHARACTER OR
NUMBER TO EDIT

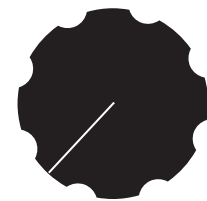

MIX
(DATA)

EXPRESSION PEDAL

Connect a TRS expression pedal to the MultiJack to control any or all of the pedal parameters remotely.

The Syntax Error² requires a TRS expression pedal, sleeve = 0V (common,) ring = 3.3V, tip = 0-3.3V. You can also use an external control voltage connected to tip and sleeve, as long as it doesn't exceed 3.3V.

If you're using a MIDI controller, you can send MIDI CC 100, value 0-127. 0 is the same as full heel setting, 127 is toe setting.

To map expression pedal values to pedal settings, first set the expression pedal to the heel setting then turn the pedal knobs. Then sweep the expression pedal to the toe setting and turn the knobs again.



HEEL SETTING



TOE SETTING

The Syntax Error² will smoothly blend between the two knob settings as you move the expression pedal. You can map any of the MAIN or ALT controls to the pedal.

If you prefer to have controls that aren't affected by the expression pedal, simply set them with the pedal heel down, then gently "wiggle" the knob with the pedal at toe down. This will set the same values for heel and toe and those knobs won't change as you sweep the pedal.

Note: sequencer settings aren't mappable to the expression pedal.

The MultiJack input is factory-calibrated for most common expression pedal types, but you can also adjust the range using the configuration menu. Tweak the EXP LO parameter to set the heel down value and the EXP HI parameter to calibrate the toe down position.

SOUND MODES

We've equipped the Syntax Error² with six unique sound modes, each designed to create a wide variety of tones. Turn the MODE knob to select a new sound mode, then use the A B X Y knobs to tune the sound to your liking. You can tap the MODE knob to access the ALT controls page, for access to four extra control functions. Every sound mode has a common set of controls:

SAMP: Sample Crusher, reduces bit depth and sample rate at higher settings.

PITCH: Sets the pitch shift interval from -1 octave to +1 octave, in semitones.

P.MIX: Sets the mix of the pitch shifter effect from dry to fully wet.

VOL: Sets the overall volume of the effect, unit is at 50%.

tone: Sets the overall brightness of the sound.

Each sound mode also has its own unique controls, accessed on the MAIN controls page.

STRETCH MODE - This mode records the input signal into a sample buffer, and then plays it back in real-time. Great for glitchy delay effects, random reverse, or freaky feedback.

PLAY sets the playback speed and direction, with forward at 0% and reverse at 100%. Middle settings will slow down and pitch down the audio.

SIZE sets the sample buffer size, shorter buffers will sound choppy

FEED controls the amount of sampled signal fed back in to the buffer, for repeat and echo effects.

AIR MODE - Grainy, lo-fi reverb effect similar to very early digital and analogue reverberation devices. Early reflections and slow build times make this a unique textural tool.

SIZE controls the decay time and simulated size of the reverb chamber effect

SOFT sets the diffusion amount, higher settings are smoother sounding

PDLY controls the pre-delay time before the reverb effect occurs.

RING MODE - Balanced "ring" modulation effect, adds extra frequencies to the original tone that are *mathematically* related but not *harmonically* related. Wild.

FREQ controls the carrier frequency of the modulator. This frequency is added and subtracted from the input.

RAND applies a random frequency for "sample and hold" dial-tone effects. Sounds like a very sick robot.

DPTH sets the range of the RAND modulation.

CUBE MODE - Math-based cubic distortion and fuzz effect, with tunable resonant filter.

DRIV controls the distortion drive amount, higher settings also add some octave fuzz

FILT sets the resonant filter cutoff frequency

RESO tunes the resonance of the filter, set to minimum to bypass the filter effect

FREQ MODE - Frequency shift effect, adds or subtracts a set frequency from the input signal. Like pitch shift but all of the intervals are broken. It's horrible.

SHFT frequency shift amount, smallest shifts are in the center of the range

FEED controls feedback, increases intensity of the shift and delay effects at high settings

DLAY sets delay time after the shift effect. Set to minimum for phaser-like tones, set to maximum for spiral echo effects.

WAVE MODE - Time based modulator, used for chorus, vibrato, flanger, and FM effects.

RATE sets the modulation speed, from very slow up to the audible band. At higher speeds the modulation is in the audio band and sounds pretty weird.

DPTH controls the amount of modulation. We let you modulate it all the way, don't complain if it gets gnarly.

FEED applies feedback to the modulation, higher settings sound more like flange and lower settings more like chorus.

MINI-SEQUENCER

The Syntax Error² includes a versatile and powerful mini-sequencer, which can control any one of the pedal knobs. This enables you to create animated textures, arpeggios, LFO effects, and more.

To enter the sequencer control mode, tap the MODE button until the page label reads SEQ.

The A B X Y knobs will directly control the values of each sequencer step, so that you can dial in or tweak the sequence at any time. The value of each step is shown by the boxes on the display bars, and the current step is indicated by the filled box.

Use the MODE knob to highlight one of the other sequencer parameters, then turn the MIX / DATA knob to set that value.

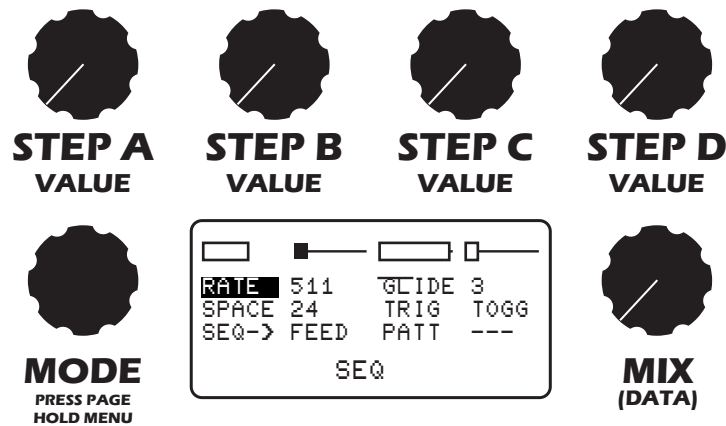

RATE: Sets the sequencer step speed, higher numbers are faster.

GLIDE: Sets the smoothness of the sequencer steps. At very low settings the sequencer will glide for a long time and may not reach the final step values.

SPACE: Sets the muting or staccato effect between sequence steps. At low settings the output will be very choppy, at high settings no muting will occur.

TRIG: Sets the sequencer trigger mode for the CONTROL footswitch.

STEP: Tap the CONTROL switch to manually select each step

ONE: Tap the CONTROL switch to run the sequence one time and then return to normal settings.

MOM: Hold the CONTROL footswitch to run the sequencer, release to stop the sequence and return to normal.

TOGG: Tap the CONTROL footswitch once to start the sequence, tap again to stop. If the TRIG mode is set to TOGG, the pedal will save the sequencer on / off state and load it as part of the preset.

SEQ->: Sets the pedal knob for the sequencer to control. All knobs are available.

PATT: Selects from 8 built-in sequencer patterns, or turn the A B X Y knobs to create your own pattern.

GLOBAL CONFIGURATION

To enter the global setup menu, first hold down the MODE knob, then press the left footswitch.

Turn the MODE knob to select the parameter you want to change, then turn the MIX / DATA knob to set its value.

Hold the MODE button to save your settings and exit the menu.

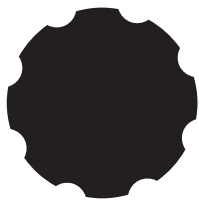

MODE
PRESS PAGE
HOLD MENU

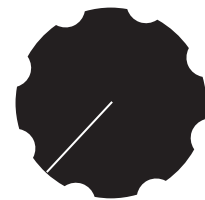
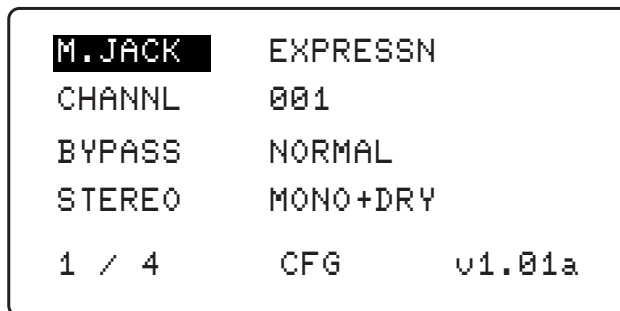

**MIX
(DATA)**

- M.JACK** **EXPRESSN** MultiJack is expression pedal input
- FOOT. SW** MultiJack is foot switch input
- MIDI** MultiJack is MIDI input (requires MIDI to TRS adapter)
- CHANNL** Sets MIDI input channel
- RPHASE** **NORMAL** R / DRY output phase normal
- INVERT** R / DRY output phase inverted
- STEREO** **MONO+DRY** INPUT jack is mono, R / DRY jack outputs dry signal
- SUM+DRY** INPUT jack sums to mono, R/DRY outputs dry signal
- STEREO** INPUT jack is stereo, L and R output stereo
- PRESET** Sets number of presets available on device. Does not affect MIDI.
- DISPLY** **STATIC** Display does not show bars or moving values
- MOVING** Display shows animated value bars
- CC OUT** **OFF** Pedal does not send MIDI CC values
- JACK** Pedal sends MIDI CC from MultiJack
- USB** Pedal sends MIDI CC from USB MIDI
- BOTH** Pedal sends MIDI CC from both
- BRIGHT** Sets display brightness
- EXP LO** Sets the heel down calibration for the MultiJack expression pedal
- EXP HI** Sets the toe down calibration for the MultiJack expression pedal
- SPLASH** Choose startup animation, set to "none" to bypass the animation.
- RESET** Turn to reset **CONFIG**, **PRESETS**, or **ALL**. Hold MODE to reset.
Set to **MIDI DUMP** to export the pedal presets over USB MIDI.

Configuration items named "ITEMxx" are not used, reserved for future expansion.

STEREO MODES

The Venture Series features advanced stereo routing capabilities, selectable in the Global configuration menu. Choose one of the following stereo modes to suit your rig or your gig.

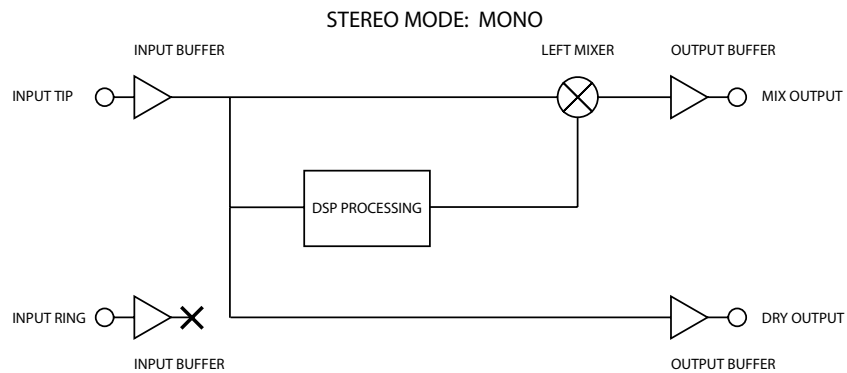

Mono Mode processes the input signal in mono, and outputs a mono signal on the L / MONO output jack. The dry signal is available on the R / DRY output jack.

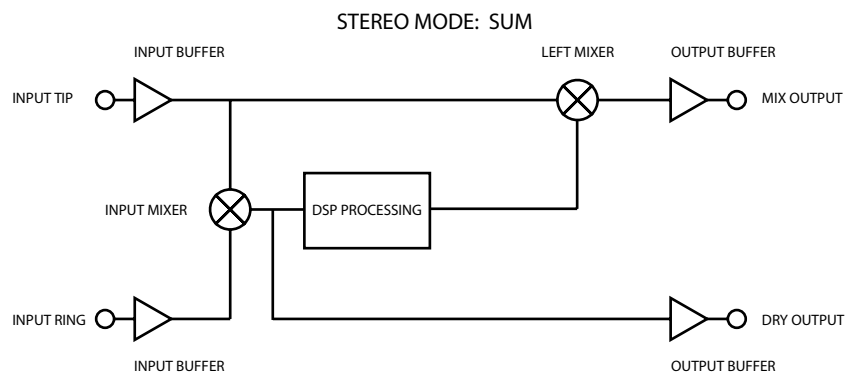

Sum mode combines left and right inputs into a mono signal for processing and outputs a mono signal on the L / MONO output. Useful if you need to sum a stereo source when using a single amplifier.

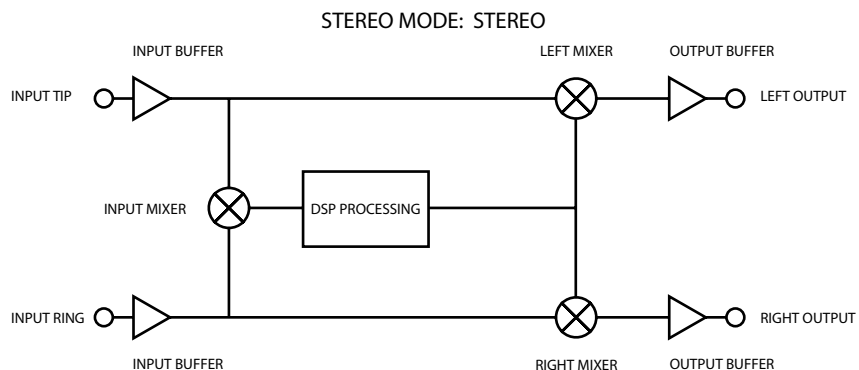

Stereo Mode preserves the separate stereo dry signals. Effect processing is based on the sum of the left and right inputs, and is split to both outputs in most modes. Some modes process the stereo image separately.

The phase of the R / DRY output may be set to normal or inverted using the configuration menu. The configuration with the better bass response is usually correct.

MIDI

The Syntax Error² features full and comprehensive MIDI implementation. Every single function and knob may be controlled by MIDI.

The pedal will accept USB MIDI at any time, or may be used with 1/4" MIDI by setting M.JACK = MIDI in the Global configuration menu. The pedal will respond to MIDI messages sent on the channel set in the Global menu only.

The 1/4" MIDI input is compatible with the Neo MIDI Cable, Neo Link, Disaster Area MIDIBox 4, 5P-TRS PRO, or 5P-QQ cables. Most other 1/4" compatible MIDI controllers should work, the pedal requires pin 5 connected to TIP and pin 2 connected to SLEEVE.

Syntax Error 2 MIDI Implementation

Command	MIDI CC	Range
SAMPLE	50	0-0127
PARAM1	51	0-0127
PARAM2	52	0-0127
PARAM3	53	0-0127
PITCH	54	0-0127
PITCH MIX	55	0-0127
VOLUME	56	0-0127
tone	57	0-0127
MIX	58	0-0127
MODE SELECT	59	0-0127
SEQ STEP A	80	0-0127
SEQ STEP B	81	0-0127
SEQ STEP C	82	0-0127
SEQ STEP D	83	0-0127
SEQ ASSIGN	84	0-9
SEQ RUNNING	85	0-64 seq off, 65-127 seq on
SEQ RATE	86	0-127 = 0-1023 rate
SEQ TRIG MODE	87	0 step, 1 one, 2 mom, 3 togg
SEQ GLIDE	89	0-127 = 0-7 glide
SEQ SPACING	90	0-127 = 0-24 spacing
EXP PEDAL	100	0-127 (heel-toe)
BYPASS	102	0-64 bypass, 65-127 engage

SPECIFICATIONS

- Input: Mono or stereo (TRS)
- Output: Mono or stereo (use either TRS or dual TS)
- Input Impedance: 1M ohms
- Output Impedance: 560 ohms
- Power Requirements: DC 9V only, 250mA or greater
- Requires isolated DC power supply
- Dimensions: 3.7" x 4.7" x 1.6" H x W x D not including knobs(120 x 94 x 42mm)
- Six sound modes
- Eight presets, expandable to 32 with a MIDI controller
- MultiJack enables expression pedal, foot switch, or MIDI input
- EXP Morph allows controlling all knobs from expression or MIDI
- Mini-sequencer for animated textures
- CTL footswitch triggers sequencer settings
- USB port for firmware updates and USB MIDI
- Buffered bypass (hybrid analog+digital)

CHANGE LOG

- 1.01
- Added bank select for presets 9-32
- Added sysex dump and restore of presets and config (fixed from 100c beta)
- Added DSP memory check - if pedal needs to update DSP it will do so automatically
- Fix issue with MIDI receive channel over 1/4" (USB was working okay)
-
- 1.00c
- clear pot values on preset load, prevents weird mess-ups
- added configuration to use alternate display types (production use only)
-
- 1.00b
- added adjustable dead zones for pots to reduce noise
- added stereo phase switching
- added expMin and expMax configuration