

MARSHMALLOW

ARTIFICIAL SWEETENER



USER MANUAL

CONTENTS

INTRODUCTION	1	SETTING UP YOUR PEDAL	6
GETTING STARTED	1	EXPRESSION PEDAL.....	7
SOUNDS AND CONTROLS.....	2	NEO FOOTSWITCH	8
LOADING AND SAVING PRESETS	4	MIDI CONFIGURATION.....	9
PITCH LOCK.....	5	MIDI COMMANDS.....	10
WARP!	5	SPECIFICATIONS.....	10



ABOUT ALEXANDER PEDALS

Alexander Pedals builds hand-crafted effects pedals in Garner, North Carolina. Each Alexander Pedal is meticulously voiced and tweaked by our sonic scientists to achieve sounds that are both instantly familiar yet completely unique.

Alexander Pedals are designed by Matthew Farrow and a group of trusted players, builders, and friends. Matthew has been building guitar pedals since the late 1990s, first with Pharaoh Amplifiers, and now with Disaster Area Designs. Matthew has designed some of the most innovative effects units on the market, including some big names he's not allowed to tell you about.

Alexander Pedals was started for two reasons - to make great tones, and to do good. The great tones part you probably have some idea about. As for doing good, Alexander Pedals donates a portion of the profits from every pedal sold to charity, whether you buy from us or our dealers. Matthew's younger brother Alex passed away in 1987 of a form of cancer called neuroblastoma. Alexander Pedals honors his memory by helping in the fight to end childhood cancer.

ALEXANDER
GREAT TONES. DOING GOOD.

2018 Garner Station Rd, Raleigh NC 27603 (919) 977-6665 alexanderpedals.com

INTRODUCTION

“Marshmallow?” That’s a silly name for a pedal, we know.

But it totally fits. Sweet, fun, and probably best consumed in small doses, our Marshmallow makes weird goopy sounds with your favorite instruments.

At its heart, Marshmallow is a pair of pitch shifters that we combine and modulate in interesting ways with a variety of magic tricks. Want smooth chorus? No problem. How about juicy organ tones? Yup. Maybe you want your stuff to sound like a cat on helium? Yes, we do that too.

Basically, Marshmallow is a quick way to start at normal and end up at “what was that?!” We hope you like it as much as we do.

GETTING STARTED

Marshmallow is pretty much like any other pedal. Plug in on the right side, then plug the lower jack on the left side to your amp or next pedal. Power it up, hit the footswitch and see what happens!

Want to hear some sounds that we like? Hold down the BYPASS footswitch to load in the factory presets. We put four cool tones in the pedal for you to tweak.

Experiment. Turn the knobs. Push the buttons. We think you’ll find something you like.

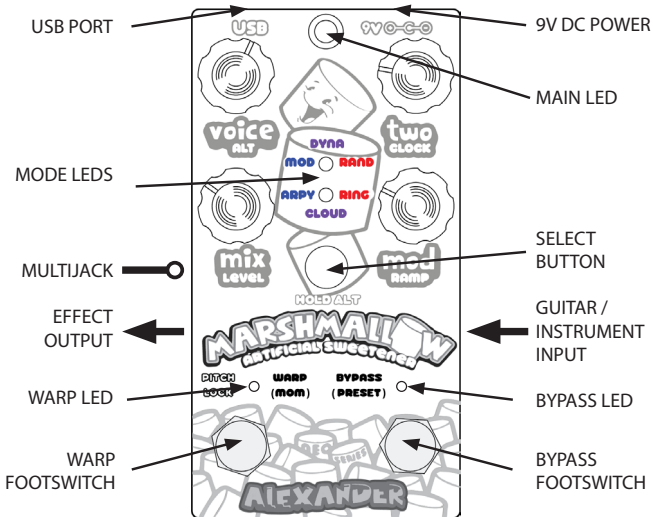

Messing with the knobs will get you a long way, but there is a lot to this pedal just under the surface. When you’re ready to dive in to the advanced features of your new pedal, read on.

SOUNDS AND CONTROLS

Marshmallow does a lot of stuff, but that doesn't mean that it's hard to use! Generally you can just turn the knobs on the pedal and explore new sounds, but we put a few extra controls on the pedal that we think you can use.

Tap the center Select button to move to the next Effect Mode. You'll notice that the small LEDs in the center of the pedal change to show the current Effect Mode.

If you *hold* the center Select button, you can access the "Alt Functions" for the pedal knobs.

Here's a run-down on what all of the knobs do in each Effect Mode of the pedal.

MOD (upper blue) Combines twin pitch shifters with an adjustable pitch modulation. Great for chorus, vibrato, and organ effects.

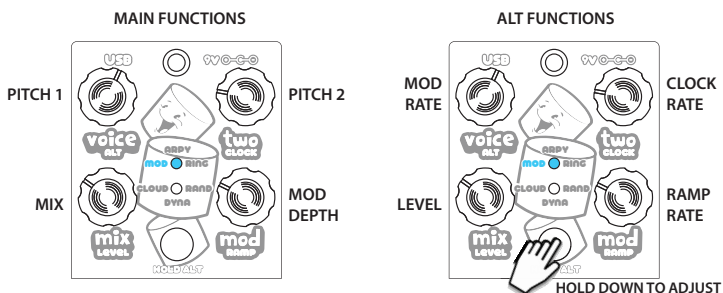

ARPY (lower blue) Fully configurable arpeggiator. The first pitch in the sequence is always unison, and you set the other three pitches with the VOICE, TWO, and MOD knobs.

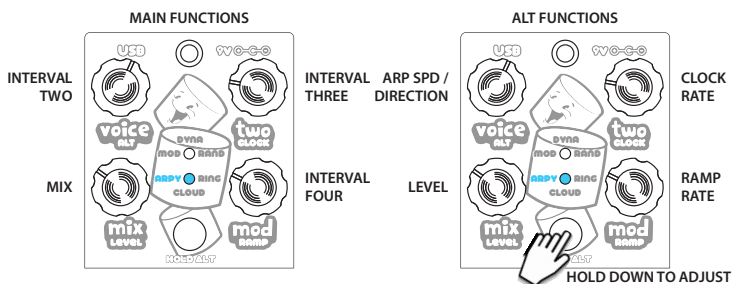

RAND (upper red) Twin pitch shifters with random modulation. VOICE and ALT set the "home" pitches of each shifter and MOD sets how far they're allowed to move.

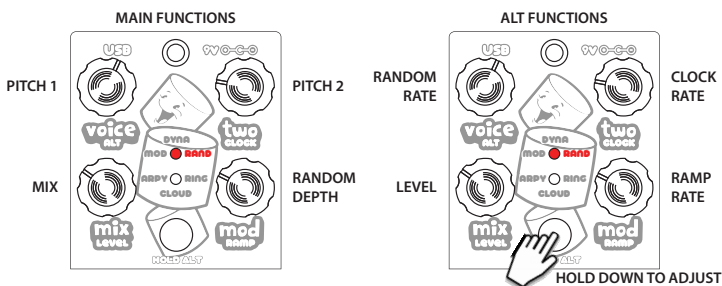

SOUNDS AND CONTROLS (CONTINUED)

RING (lower red) Twin pitch shifters with an adjustable fade / tremolo effect. Low settings of MOD sound like tremolo or panning, higher settings sound like robot barf.

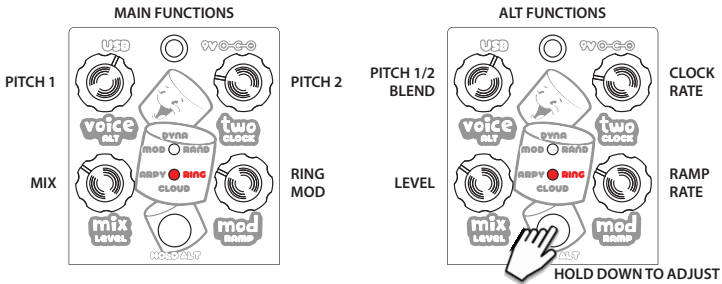

DYNA (upper violet) Dynamically controlled pitch shifter. VOICE sets the “quiet” interval and TWO sets the “loud” interval. Adjust MOD to control the sensitivity of the envelope detector. ALT sets the shift behavior to either glide between pitches or smoothly fade.

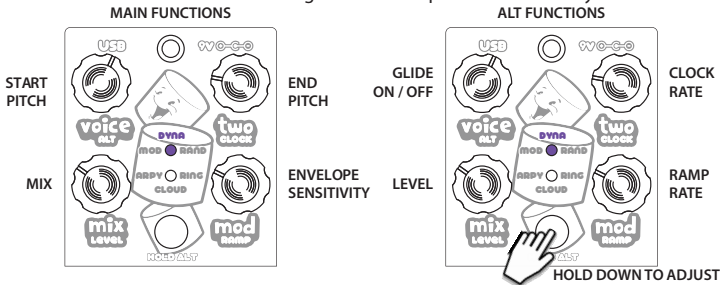

CLOUD (lower violet) Twin pitch shifters with an adjustable cascading delay / reverb effect. Increase the MOD knob for more clouds, lower the CLOCK knob for longer delays.

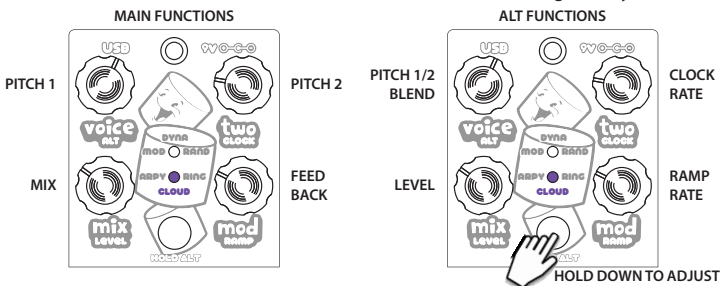

LOADING AND SAVING PRESETS

Have you ever spent a lot of time tweaking your gear to get the sounds you really love, only to find that your pedal knobs moved between your practice space and the gig? Or maybe you need a lot of sounds but don't have a ton of room on your board for multiple pedals?

Presets to the rescue!

Marshmallow and all of our other Neo Series pedals have built-in preset capability. That means you can save and recall four sounds from a single pedal with no extra hardware or funny business. If you do have a MIDI controller, the preset capability expands to 16!

To load a preset, simply hold down the BYPASS footswitch for 1 second.

The upper LED will blink one, two, three, or four times to indicate the current preset and you're all set!

ALL of the pedal settings are recalled as part of the preset - knob positions, expression settings, and effect modes.

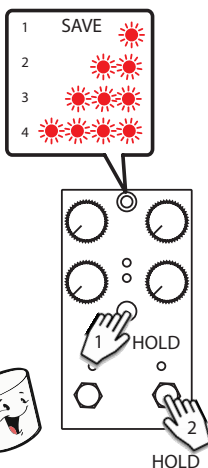
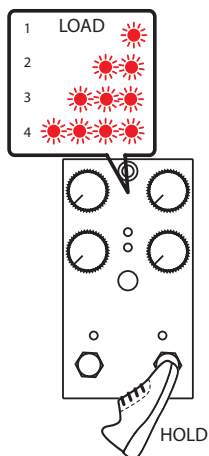

To save the current preset, press and hold the center Select button, then hold the BYPASS footswitch down.

The upper LED will blink to indicate the preset that was saved.

If you're using a MIDI controller to access presets on your Neo Series pedal, just send a program change (PC) message to load a preset.

You can access an additional 12 presets using MIDI for a total of 16.

To save presets 5-16, load in the preset by sending a MIDI program change then edit its settings. Once satisfied, save as normal. The current settings will save in the current preset.

PITCH LOCK

While it is fun to pitch shift to random intervals, it's also cool to lock in to musical pitches. To help you get the most out of your Marshmallow, we've added in Pitch Lock, which "snaps" the range of the pitch shifters to different tuned intervals.

To change the Pitch Lock setting, hold down the center Select button and then hold the RAMP footswitch. The upper LED will change to indicate the current Pitch Lock setting.

The four settings are:

UNLOCK (violet) No lock, pitch is fully variable.

CHROMATIC (yellow) Pitch locks to semitone / half-step intervals.

MAJOR (cyan) Pitch locks to the major scale intervals.

MINOR (green) Pitch locks to the minor scale intervals.

The Pitch Lock settings are saved as part of your presets.

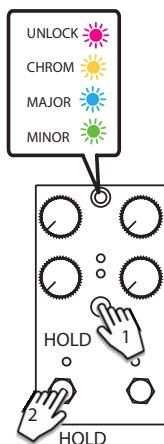

WARP!

Marshmallow features an advanced expression functionality we call WARP! This allows you to seamlessly morph between two different pedal settings with a single tap of your toe.

Tap the left footswitch on the pedal to begin the WARP effect - you will see the WARP LED light up and the main LED will fade from white to blue if the pedal is engaged. You will then hear the pedal slide from its current settings to the WARP settings.

If you want to engage WARP for a short time, for example to accentuate a phrase, you can hold the left footswitch to engage then release to go back to normal.

To set the normal and WARP sounds on Marshmallow, first tap the left footswitch until the WARP LED is off.

Next, turn the knobs to set the sound you want for the normal setting. Please note that the alternate knob functions may also be set at this time!

Finally, tap the left footswitch until the WARP LED is on and set the knob positions as desired for your WARP sound!

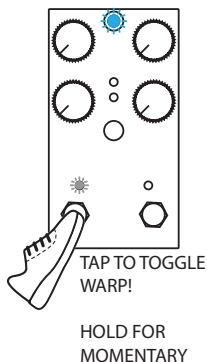
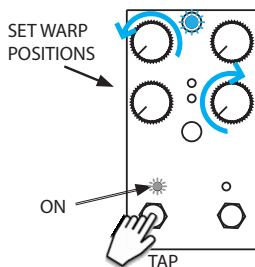
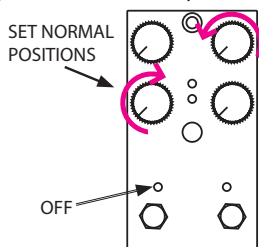

You can set the WARP to activate instantly or slowly - hold the Select button and turn the RAMP knob to set.

SETTING UP YOUR PEDAL

Your Neo Series pedal has a few user settings stored in memory. These settings include the function of the MultiJack on the left side of the pedal, LED brightness, and others.

To enter setup, power on the pedal and then hold down the center Select button. Release the button when you see the center LED turn violet.

Tap the center Select button to assign the MultiJack function. The upper small LED will change to show this function.

- Blue:** Expression Pedal Input
- Violet:** Footswitch Input
- Red:** MIDI Input

Turn the upper left knob to set the function of the external footswitch, if configured. The upper large LED will change to show this function.

- Green:** Trigger Ramp
- Cyan:** Advance One Preset

Turn the lower right knob to set the brightness of the main and lower LEDs.

The lower left knob sets the dry signal routing in effect mode.

- Blue:** Analog dry signal, clean signal at all times.
- Red:** DSP dry signal, better phase response but the dry signal gets darker at lower clock rates.

Hold the center Select button to save and exit setup.

If you have changed the function of the MultiJack, we recommend you power the Neo Series pedal off and back on in order to ensure the jack is configured properly.



HOLD TO ENTER SETUP
RELEASE WHEN LED TURNS VIOLET

- GREEN = RAMP**
- CYAN = PRESET**

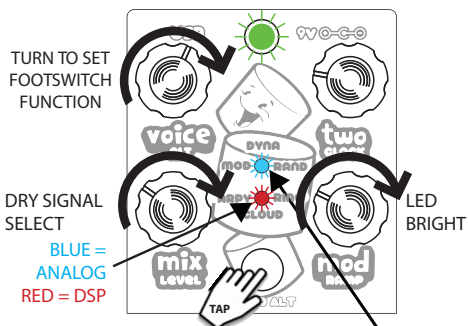

TAP TO SELECT MULTI JACK FUNCTION
UPPER PROGRAM LED WILL SHOW
BLUE = EXPRESSION PEDAL
VIOLET = FOOT SWITCH
RED = MIDI



HOLD TO SAVE AND EXIT

EXPRESSION PEDAL

Marshmallow supports most types of expression pedals for performance control.

We recommend the Roland EV-5 and Moog EP-3, but just about any expression pedal that uses a TRS cable should work. The supported expression wiring is **SLEEVE = 0V, RING = 3.3V, TIP = 0-3.3V**.

Before connecting your expression pedal, make sure that you have set up the MultiJack to read expression! The instructions are covered in the [Setting Up Your Pedal](#) section on page 6.

The expression pedal can control all of the pedal knobs, just like the WARP footswitch. The big difference is that the WARP footswitch always ramps between settings at the rate you set with the RAMP knob, and the expression pedal ramps as you move the pedal.

You can use the WARP footswitch to set the expression pedal values, and vice versa. This allows you to connect an expression pedal when you have room on your board or use the WARP footswitch when you don't!

Connect your expression pedal to the MultiJack with a TRS cable. Engage the pedal and sweep the pedal - you should see the upper LED change colors and the sound should change.

Set the expression pedal to its HEEL DOWN position.

Turn the pedal knobs to set the sound you want for the HEEL DOWN position.

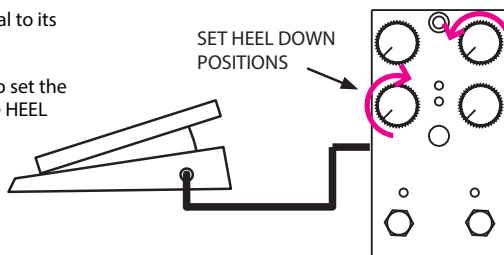

Next, set the expression pedal to its TOE DOWN position.

Move the knobs to the desired settings for TOE DOWN.

That's it!

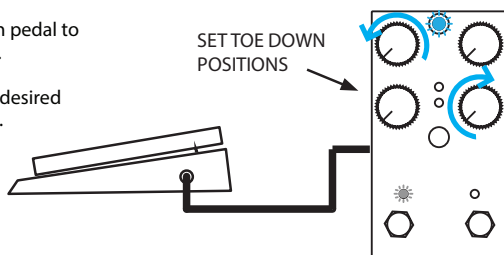

Just like with the WARP footswitch, all of the knobs on the pedal can be controlled with the expression pedal except RAMP RATE, PITCH LOCK, and the mode selection.

Once you have set the sounds you like, don't forget to save your preset! Changes you make to a preset are lost if you power off the pedal or load another preset without saving!

NEO FOOTSWITCH

Marshmallow also supports our Neo Footswitch for preset Select or warp functions.

To use the Neo Footswitch, you'll need to configure Marshmallow to use its MultiJack for footswitch input. Consult the instructions on page 6, [Setting Up Your Pedal](#).

Connect the Neo Footswitch to your Marshmallow using the provided TRS cable.

If you have configured the pedal correctly, you should see the LED on the Neo Footswitch light up and change as you tap the footswitch.

PRESET:

Tap the Neo Footswitch to advance one preset. The presets will load in sequence, 1, 2, 3, 4.

The LED on the Neo Footswitch will change to indicate the current preset:
RED = 1, GREEN = 2, BLUE = 3, YELLOW = 4.

Hold the Neo Footswitch to go back one preset.

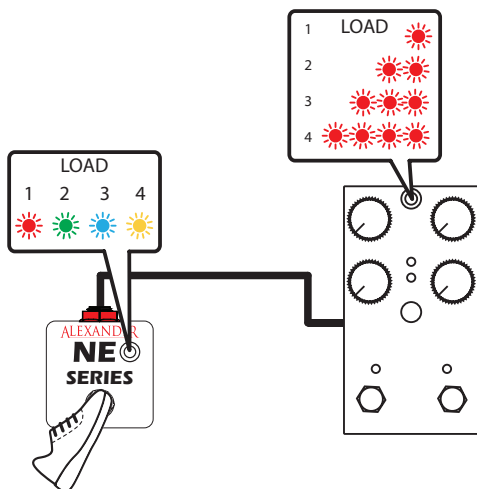

RAMP:

Tap the Neo Footswitch to trigger the WARP effect.

The LED on the Neo Footswitch will change to indicate the current WARP state.

You can also fire the ramp for a moment, by holding the Neo Footswitch down. The ramp will fade back down when you release the Neo Footswitch.

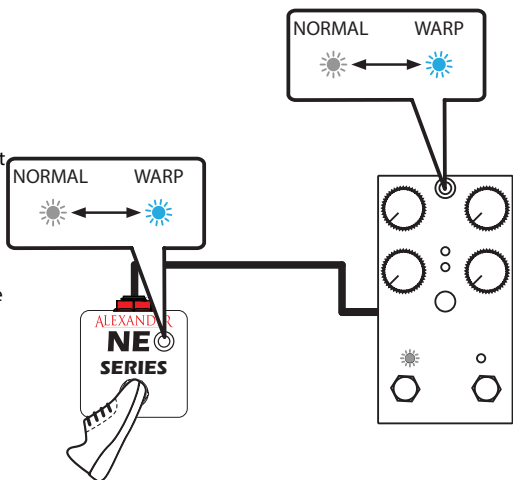

You can also use any momentary normally-open (NO) footswitch in place of the Neo Footswitch, but you won't get the super-cool LED stuff.

MIDI CONFIGURATION

All Neo Series pedals support full control using MIDI. In order to use your Marshmallow with a MIDI controller, you'll need to follow these instructions to configure its MultiJack and set up the MIDI channel.

First, you'll need a way to connect your MIDI controller to the MultiJack.

If you're using a Disaster Area Designs controller, you should be able to use one of its MultiJacks to send MIDI. We recommend the qCONNECT controller, since it's made to interface with multiple 1/4" MIDI devices. Consult your MIDI controller's manual for details on how to configure its output.

If you are using another type of MIDI controller, you'll need an interface box or adapter cable.

We support the following interfaces and cables:

Alexander Neo Link
Disaster Area Designs MIDI Box

Alexander Neo MIDI Cable
Chase Bliss Audio MIDI Box

Next, connect your Neo Series pedal to your MIDI controller or interface box using a standard 1/4" cable or adapter cable. Make sure that your controller is powered on.

Power on the Neo Series pedal while holding its center Select button. Release the button when the main LED turns violet. Tap the center Select button until the upper small LED is red, then hold Select to save.

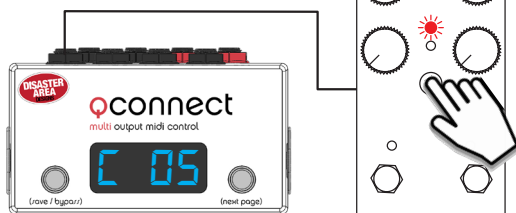

Power the Neo Series pedal off and back on, again holding the center Select button until the upper LED turns violet.

Send a program change message from your controller on the MIDI channel you would like to use. When you see the upper small LED flash, hold the Select button to save and exit.

Your Neo Series pedal is now configured!

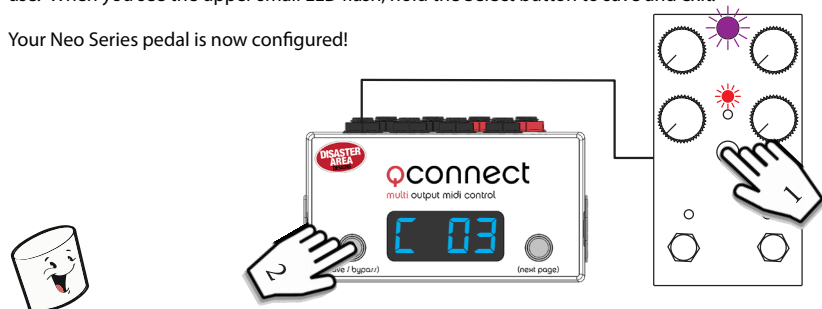

MIDI COMMANDS

All of the functions of your Neo Series pedal may be controlled with MIDI messages.

The following commands are accepted by Marshmallow:

MIDI Program Change: Load Presets 0-15

0-3 are the Red bank, also accessible by holding the Bypass / Preset footswitch

4-7 are the Green bank

8-11 are the Blue bank

12-15 are the White bank

MIDI Continuous Controller 97: Ramp

Send any value to trigger the ramp

MIDI Continuous Controller 100: Expression Pedal

Value 0 = Heel down, Value 127 = Toe down

MIDI Continuous Controller 102: Bypass

Value 0-63 = Bypass, Value 64-127 = Engage

MIDI Continuous Controller 50-57: Pedal Knobs

Value 0 = CCW, Value 127 = CW

CC 50 = Mod

CC 51 = Voice

CC 52 = Two

CC 53 = Mix

CC 54 = Ramp Rate

CC 55 = ALT

CC 56 = Clock

CC 57 = Level

MIDI Continuous Controller 58: Pitch Lock

0: UNLOCK

1: CHROMATIC

2: MAJOR

3: MINOR

MIDI Continuous Controller 59: Mode Select

0: MOD

1: CLOUD

2: RING

3: RAND

4: ARPY

5: DYNA

Marshmallow does not respond to MIDI Beat Clock and does not have tap tempo capability.

SPECIFICATIONS

Input Impedance: 1M ohm

Output Impedance: 560 ohm

Power Supply: 9V DC, 80mA or greater, center negative

Bypass: Buffered analog bypass

Dry Signal: Analog or DSP (selectable)

DSP: 24-bit + 32-bit controller

Sampling Frequency: 36kHz -> 6.66kHz



We recommend the use of an isolated power supply with your Neo Series pedal.